

Racing manual

Öhlins super bike front fork FG 9700

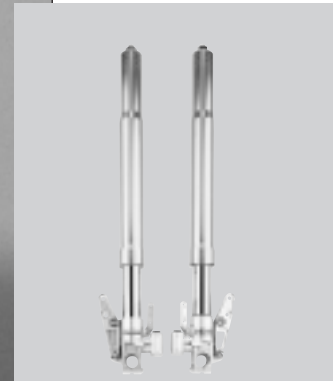

Including:
**Setting up
your fork**

**Changing
springs
and seals**

**Service
the fork**

**Trouble
shooting**

**Technical
info**

**Spare parts
& tools**

Traction, handling,
comfort and safety



ADVANCED SUSPENSION TECHNOLOGY

Öhlins super bike front fork FG 9700

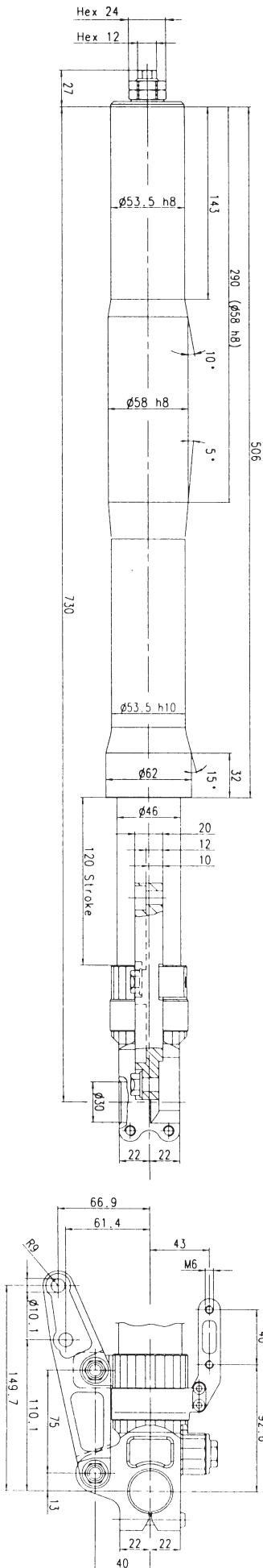

Contents

Introduction	2
Setting up your forks	
Spring preload adjustment	3
Rebound adjustment	
Compression adjustment	
Changing springs	
Changing seals	
Dismantling the forks	4
Assembly of the forks	
Troubleshooting	
Oil level adjustment	5
Technical information	
Spare parts	6
Tools	

Safety signals

Particularly important information is distinguished in this manual by the following notations:



The Safety Alert Symbol means: ATTENTION! BECOME ALERT! YOUR SAFETY IS INVOLVED!

WARNING

Failure to follow WARNING instructions could result in severe injury or death to the shock absorber operator, a bystander or a person inspecting or repairing the shock absorber.

CAUTION!

A CAUTION indicates special precautions that must be taken to avoid damage to the shock absorber.

NOTE!

A NOTE provides key information to make procedures easier or clear.

Introduction

The Öhlins front forks use a Cartridge system for damping. This gives a damping force which depends on the speed of the piston in the cartridge system.

The combination of spring and air-gap (oil level) gives a possibility to adjust the characteristic of the fork to suit different tracks and riders.

For example a soft spring in combination with a small air-gap (high oil level) gives a progressive action of the front forks.

For better understanding, please refer to our oil level chart.

A telescopic front fork is depending on a smooth friction-free action.

Make sure your front forks are serviced regularly and don't use strong solvents such as brake cleaner to clean the front forks. This will dry out the seals and steel tubes and cause friction.

Regularly, put a little Öhlins grease (148-01) on the steel tube and work it in by pushing the forks up and down.

Öhlins Racing AB can not be held responsible for any damage to spare parts or person if the mounting-, maintaining- and servicing instructions are not followed exactly.

Also no guarantee can be given for the performance and reliability if these instructions are not followed.

Setting up your forks

We would like to give you some basic guidelines, how to set up your Öhlins front forks. However you must remember that the front forks are just one part of your motorcycle and to get it to work properly, the whole motorcycle has to be set up according to your bikes manual.

1

Put your bike on a front stand so you can fit the front forks.

Maximum torque on the bottom triple clamp and steering damper bracket (if it is located on the diameter on the outer tube) is 15-18 Nm.

Fit the front wheel and brakes.

2

Unscrew the adjustment housing on top of the fork (use tool 797-01) on both upper tubes and slide the fork up and down gentle to make sure everything works correctly.

3

Assemble the adjustment housing again and set your initial preload of the spring by using a 12 mm socket until you get a "static sag" of 25-30 mm.

© Öhlins Racing AB.
All rights reserved.

Any reprinting or unauthorized use without the written permission of Öhlins Racing AB is prohibited.

Printed in Sweden.

Each turn gives 1 mm in preload, maximum preload is 18 mm.

4

The best way to check the "static sag" is to put the bike on the ground in running condition.

Measure the distance between the bottom of the outer tube to the fork bottom.

Then lift the front end of the bike, so the fork is fully extended.

Take the measurement again. The difference between those two figures is "static sag".

5

The "clickers" are a "bleed function" separate for rebound and compression damping.

Rebound is on the top centre of the fork and compression at the bottom part of the fork.

You start to count from fully closed (clockwise) and set it to the recommended "click" (use tool 794-01).

For recommended start setting please refer to the specification card.

Spring preload adjustment

Using a 12 mm wrench, turn the upper adjustment screw.

Maximum adjustment range is 18 mm.

One turn on the adjustment screw will cause 1 mm change in spring preload.

Adjust so the front forks lowers 25-30 mm from the top, unloaded position.

Rebound adjustment

Adjust the rebound rate on the adjustment screws positioned at the top centre of the front forks.

Use a hex key with a spherical head (use tool 794-01).

Adjustment range from closed valve (clockwise) until maximum open valve (anticlockwise) is 20 "clicks".

Recommended adjustment "click", from closed position (see specification card).

Compression adjustment

Adjust the compression rate on the lower part of the front forks (compression valve). Use a hex key with spherical head (use tool 794-01).

Adjustment range from closed valve (clockwise) to maximum open valve (anticlockwise) is 20 "clicks".

Recommended adjustment "clicks", from closed position (see specification card).

Changing springs

1

Loosen the screws that hold the fork legs in the upper triple clamps.

2

Loosen the adjustment housings (pos 7, page 7) about two turns (use tool 797-01).

3

Remove the fork legs from the motorcycle.

4

Fasten a fork leg in a vice. Use soft jaws.

5

Unload the spring completely by turning the adjustment screw completely anticlockwise. Use a 12 mm wrench.

Remove the blue locking nuts.

6

CAUTION!

Do not damage the o-ring and do not drop the flat key into the fork leg.

Carefully remove the adjustment housing.

7

Remove the preload tube and spring. (The free spring length see page 5).

8

Install the new spring and check the oil level.

Install the tool 1765-01 on top of the preload adjustment screw.

Pull out the piston rod as far as possible and turn the compression adjustment screw fully clockwise.

This will keep the piston rod in top position, which will make the continued assembly easier.

9

Install the preload tube.

Install the tool 1766-01 on top of the preload tube and fasten it below the edge of the preload adjustment screw (pos 18, page 7).

Remove the tool and continue the assembling.

10

Install the adjustment housing.

CAUTION!

*The flat key must be guided in the slot of the adjustment housing.
The o-ring must be greased, or it might be damaged.*

11

Install the two blue nuts.

12

Loosen the preload tube, and bring it to its correct position in the adjustment housing.

Tighten the lower lock nut gently, and then unscrew it 1/4 of a turn.

Tighten the upper gently against the lower nut.

Fasten the adjustment housing in the fork leg.

Make sure that the fork leg is fully extended when tighten the adjustment housing.

13

Install the fork legs on the motorcycle and adjust the preload, compression and rebound according to the above instructions.

Changing seals

Put the fork legs upright for 15 minutes.

1

Fasten the fork leg in a vice. Use soft jaws.

2

Unload the spring preload completely by turning the adjustment screw completely anticlockwise. Use a 12 mm wrench.

Make a note of the number of turns.

Remove the two blue lock nuts.

3

Carefully remove the adjustment housing.

CAUTION!

Do not damage the o-ring and do not drop the flat key into the fork leg.

4

Remove the preload tube.

5

Slide the outer fork leg up until the top bushing is just above the inner leg. (Approx. 140 mm from complete bottom position.

This is to make sure there is no oil above the top bushing).

6

Slide the outer tube completely down. (Fork seal touching fork bottom).

7

Push the piston rod down so that it is in level with the top of the outer tube.

NOTE!

When measuring the oil level, always have the spring installed.

Measure the oil level using the top of the outer tube as the zero mark. Note the measurement.

8

Remove the spring and tip the oil in a clean container.

9

Remove the outer tube, clean the seals and check for damaged, if the seals are damaged remove and replace.

If the seals are OK, then apply with Öhlins grease (green grease 148-01).

10

Apply Öhlins fork oil on the seals and on the inner tube.

12

Carefully mount outer tube (slide completely down) install spring and set the oil level.

13

Go on with 9 to 13 according to page 3 "Changing springs".

Dismantling the forks

1

Carry out 1 to 7 of page 3 "Changing springs".

2

Free the fork leg from the vice and drain the oil.

3

Pull up the outer tube and remove the seals.

4

Fasten the inner tube on the fork bottom in a vice. Use soft jaws!

5

Unscrew the seal head (pos 24, page 7) from the cartridge tube and remove the piston rod unit (use tool 1797-01).

Drain the remaining oil.

6

Remove the complete compression valve use a 17 mm wrench.

7

Remove the piston and the shims from the piston rod and compression valve. Place the shims in their correct position on the work bench.

8

Clean all parts thoroughly and dry with

compressed air.

Assembly of the forks

1

Apply a thin layer of Öhlins green grease (148-01) on the scraper ring and on the sealing surfaces of the fork seal.

Install the seals in the outer tube.

Please note that it is important to use the correct grease in order to achieve optimum fork function.

2

Install the piston and the shims on the piston rod and the compression valve.

Tighten the 6 mm lock nuts with a torque of 0.6 Nm.

Check the piston ring for damages. Replace if necessary.

3

Install the compression valve assembly into the valve housing.

4

Apply some front fork oil 1305-01 on the inner steel tube surface and install the outer aluminium tube.

Measure the correct amount of 1305-01 oil according to the specification card.

CAUTION!

Be careful not to damage the fork leg seals.

5

Raise the outer tube approximately 120 mm and fill the oil.

Install the complete piston rod into the cartridge tube.

6

Lightly tighten the seal head using tool 1797-01.

7

Pump the piston rod up and down and the oil will be sucked into the cartridge tube. Close the "clickers" and check the function.

8

Pull the piston rod out as far as possible and close the compression valve screw completely (clockwise).

9

Go on with 8 to 13 according to page 3 "Changing springs".

Trouble shooting

We like to give a few examples which

are common in Road Racing and how to solve them.

A

The front wheel "chatters" entering a corner, the problem goes away, as soon as you let the brakes off, or when you get on the power.

This is caused by the fact that the fork is working too low in the travel and reaches the progressive, hard part at the end of the travel.

1

Put on more preload.

2

Change to a harder spring.

3

If a lot of stroke remains after riding, drop the oil level. See oil level chart.

4

Make sure the front forks have no friction.

5

Rear ride height is too high, too much rear spring preload.

Lower the rear end by taking off preload from rear shock spring.

B

The front wheel is jumping during the last part of braking.

1

If a lot of stroke remains, the oil level is too high. Lower the oil level.

2

If the fork is bottoming, put in harder springs and keep the oil level.

C

The front end feels unpredictable and unsafe in the middle of the corner (between braking and getting on power).

1

Not enough rebound damping. Put on more damping.

2

Too much rebound damping. If it at the same time feels harsh, take off some rebound damping.

3

Too much compression damping. Also gives a harsh feeling. Take off some compression damping.

D

The front end loses grip coming out of a corner.

1

Not enough rebound damping. Put on some more rebound damping.

2

Too much preload. Take off some preload.

3

Rear end is too soft. Put on a harder rear spring.

4

Front end is too high. Lower the front end by pulling the fork legs through the triple clamps.

As mentioned in the beginning, the whole bike setup affects the front forks. Try to understand the feelings and work step by step.

NOTE!

Our advice is to change only one thing at a time and do everything step by step.

Oil level adjustment

Compared with conventional type of front forks, the upside down front forks are very sensitive to variations in oil level. Therefore, adjust the oil level with special care.

A change in the fork oil level will not affect the damping force at the early

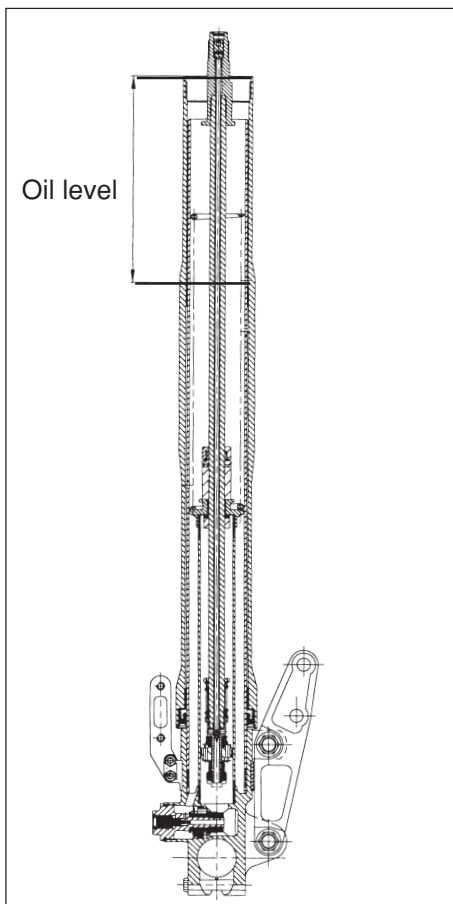

Air spring characteristics

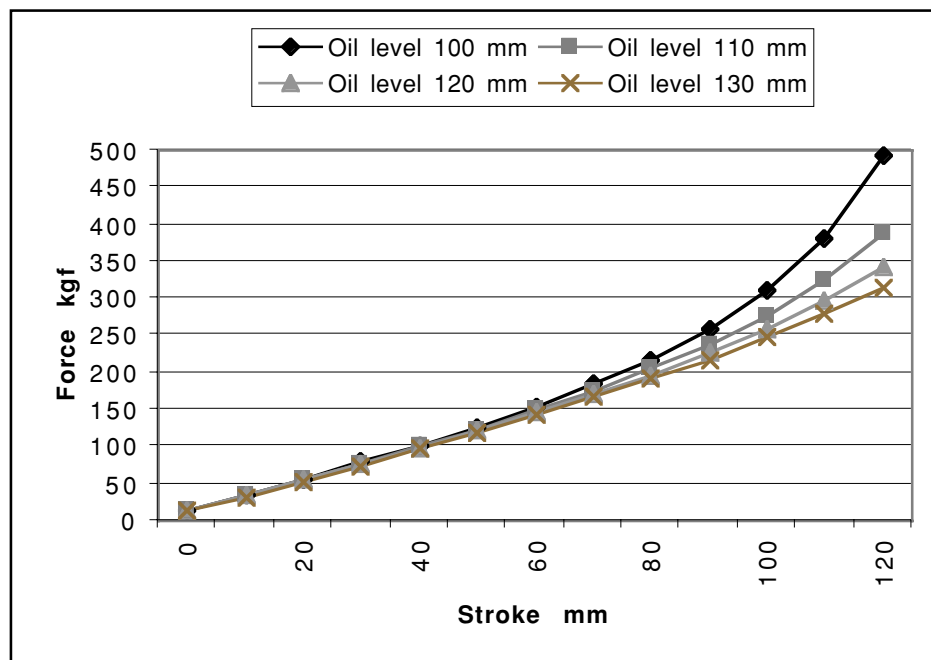

stage of the fork travel, but will have a great effect at the later stage.

When the oil level is raised:

The air spring in the later half stage of travel is stronger, and thus the front forks harder.

When the oil level is lowered:

The air spring in the later half stage of travel is lessened, and thus the front forks are softer.

The oil level works most effectively at the end of the fork travel.

Air spring characteristics shown, is a general card description to understand the difference when the oil level is changed.

NOTE!

Adjust the oil level in mm according to the figure with the fork fully compressed and with the spring mounted.

For the right STD-level, please see the specification card.

Technical information

Fork length:

730 mm.

Stroke:

120 mm.

Free spring length:

230 mm.

Rebound adjustment:

Base setting 9-12 "clicks".

Maximum open valve 20 "clicks".

Compression adjustment:

Base setting 6-16 "clicks".

Maximum open valve 20 "clicks".

Spring preload adjustment:

0-18 mm (0-18 turns).

Spring rate:

1596-95, 9.5 N/mm (marking -95).

Optional springs supplied:

1596-10, 10.0 N/mm (marking -10).

1596-90, 9.0 N/mm (marking -90).

Optional springs:

1596-85, 8.5 N/mm (marking -85).

1596-80, 8.0 N/mm (marking -80).

Oil Capacity:

Please see specification card.

CAUTION!

Use only Öhlins high performance front fork fluid No. 5 (1305-01).

Loctite glue:

542 on Fork Bottom thread.

Tighten torque:

Triple Clamp bolt 15-18 Nm.

Grease:

Öhlins front fork grease 148-01 (green grease).

Service interval:

Every 10 hours.

Notes

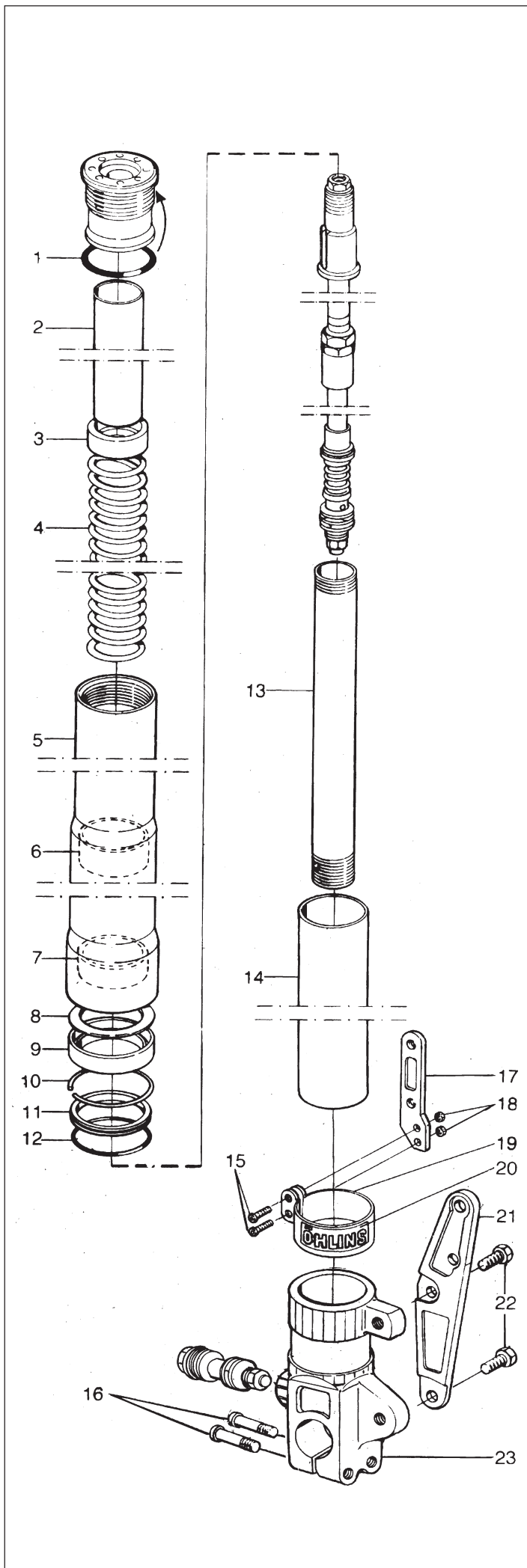

Spare parts

Fig.	Part No.	Description	Pieces
1-01	00338-65	O-ring	2
1-02	01460-33	Preload tube	2
1-03	01438-02	Guide ring	2
1-04	01596-90	Spring, 230/0.90	2
1-04	01596-10	Spring, 230/1.0	2
1-04	01596-95	Spring, 230/0.95	2
1-05	01689-02	Fork leg outer	2
1-06	01627-01	Bushing	2
1-07	01626-01	Bushing	2
1-08	01552-01	Washer	2
1-09	01524-01	Seal	2
1-10	01553-01	Circlip	2
1-11	01565-01	Stroke indicator	1
1-12	00338-63	O-ring	1
1-13	01656-01	Cylinder tube	2
1-14	01525-02	Fork leg inner	2
1-15	01046-19	Bolt	4
1-16	01240-01	Bolt	4
1-17	01591-01	Fender bracket	2
1-18	00430-04	Nut	4
1-19	01564-01	Fender bracket	2
1-20	00194-10	Sticker	2
1-21	01593-01	Caliper bracket LH	1
	01593-02	Caliper bracket RH	1
1-22	01239-03	Bolt	4
1-23	01666-01	Fork bottom LH	1
	01666-02	Fork bottom RH	1

Service tools

Part No.	Description
0787-04	Cylinder tube tool (cartridge)
0797-01	Pin sleeve tool
0786-03	Inner tube tool
1797-01	T-handle
0794-01	Hex key with spherical head
1765-02	Pull-up top-out spring tool
1766-01	Preload tube pusher

Spare parts

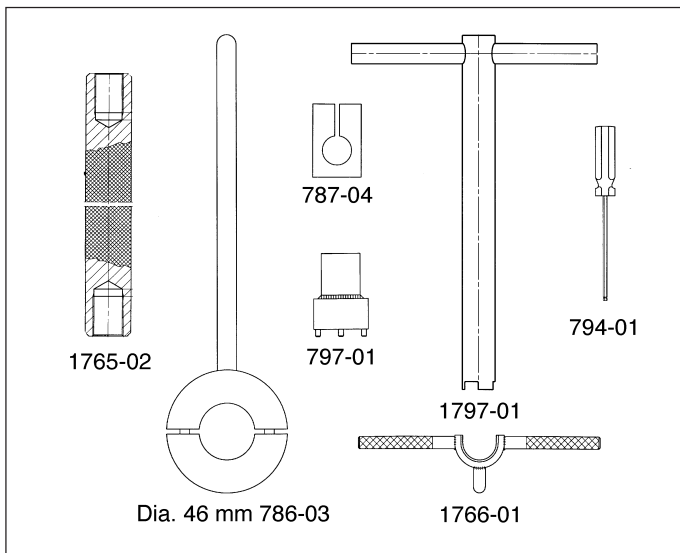
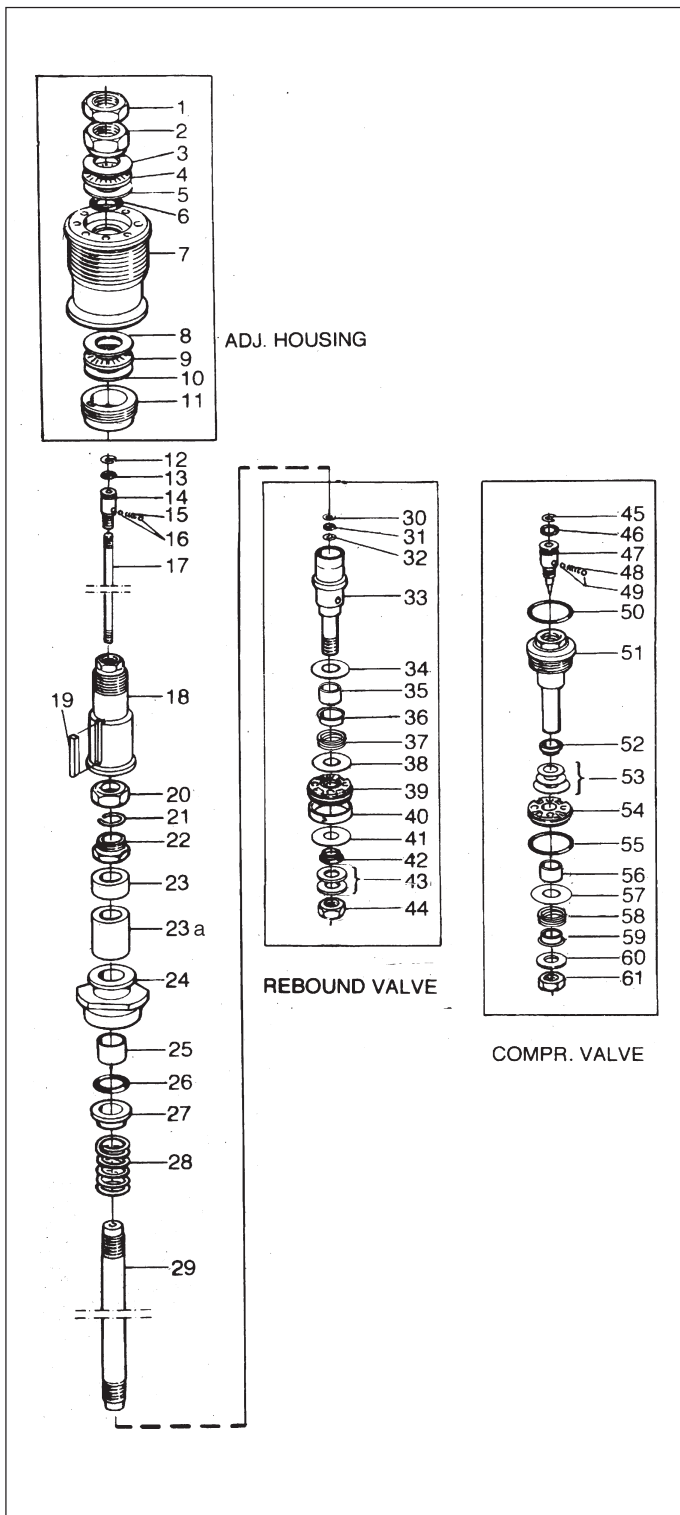

Fig.	Part No.	Description	Pieces
2-01	01059-04	Nut	2
2-02	01059-05	Nut	2
2-03	01437-01	Thrust washer	2
2-04	01403-01	Thrust needle bearing	4
2-05	01437-01	Thrust washer	2
2-06	00338-22	O-ring	2
2-07	01468-02	Adjustment housing	2
2-08	01437-01	Thrust washer	2
2-09	01403-01	Thrust needle bearing	4
2-10	01404-01	Thrust washer	2
2-11	01408-01	Adjustment driver	2
2-12	01473-01	Circlip	2
2-13	00577-01	O-ring	2
2-14	01467-01	Adjustment screw	2
2-15	01474-01	Spring	2
2-16	00884-04	Ball	4
2-17	01673-01	Adjustment needle	2
2-18	01469-05	Adjustment screw	2
2-19	01407-02	Flat key	2
2-20	01648-01	Lock nut	2
2-21	01499-02	Circlip	2
2-22	01649-01	Stop screw	2
2-23	01582-11	Spacer	2
2-23a	01580-01	Bump rubber	2
2-24	01651-01	Seal head	2
	00110-01	Bushing	-
2-25	01582-10	Spacer	2
2-26	00438-28	O-ring	2
2-27	01653-01	Sleeve	2
2-28	01585-01	Topout spring	2
2-29	01644-01	Shaft	2
2-30	01508-01	Back-up ring	2
2-31	00338-14	O-ring	2
2-32	01508-01	Back-up ring	2
2-33	01654-02	Piston holder	2
2-34	00530-16	Shims	2
2-35	01669-01	Sleeve	2
2-36	01672-01	Spring collar	2
2-37	01671-02	Spring	2
2-38	00530-22	Shim	2
2-39	02061-01	Piston	2
2-40	01447-02	Piston ring	2
2-41	-	Shim, see spec.card	-
2-42	00641-01	Washer	2
2-43	01674-01	Washer	6
2-44	01657-01	Nut	2
2-45	01473-02	Circlip	2
2-46	00338-53	O-ring	2
2-47	01242-05	Adjustment needle	2
2-48	01474-01	Spring	2
2-49	00884-02	Ball	2
2-50	00438-02	O-ring	2
2-51	01658-02	End piece	2
2-52	01652-02	Washer	2
2-53	-	Shim, see spec.card	-
2-54	01670-01	Piston	2
2-55	00338-11	O-ring	2
2-56	01669-01	Sleeve	2
2-57	00530-22	Shim	2
2-58	01671-01	Spring	2
2-59	01672-01	Spring collar	2
2-60	00120-01	Washer	2
2-61	01657-01	Nut	2
1	07280-05	Owner's manual	

Öhlins distributors

Motorcycles

AUSTRALIA

Steve Cramer Proucts, BRAESIDE, Tel. +61 3 9587 1466, Fax. +61 3 9587 2018

AUSTRIA

Motopart Handelsges. m.b.H., WIEN, Tel. +43 1 667 6628, Fax. +43 1 667 0696

CANADA

S. Hans Racing Products, EDMONTON, Tel. +1 403 466 8653, Fax. +1 403 465-9483

CROATIA

Moto ZIP trgovina d.o.o., KRANJ, Tel: +386 64 268 515, Fax: +386 64 268 514

DENMARK

F.I. Motorcykler ApS, SORÖ, Tel. +45 57 833 348, Fax. +45 57 834 855

FINLAND

Mauri Penttilä Racing, HYVINKÄÄ, Tel. +358 19 437 100, Fax. +358 19 489 872

FRANCE

P.F.P - Öhlins France, Arpajon-Sur-Cere, Tel. +33 471 481 534, Fax. +33 471 642 593

GERMANY

Zupin Moto-Sport GmbH, TRAUNREUT, Tel. +49 8669 85760, Fax. +49 8669 2328

GREECE

Vassilis Dulaveris, ATHENS, Tel. +30 1-923 6051, Fax. +30 1-924 9957

HONG KONG

Power Motorcycle Specialist, KOWLOON, Tel. +852 3903 949, Fax. +852 3919 434

ICELAND

Baldurssons Trading, AKUREYRI, Tel: +354 8545 3136, Fax: +354 462 2777

ITALY

Motorquality S.p.A., SESTO S GIOVANNI (MI), Tel. +39 02 249 511, Fax. +39 02 2495 1232

JAPAN

Carrozzeria Japan Co., Ltd., SAITAMA-PREF; 336, Tel. +81 48 863 1801, Fax. +81 48 863 1802

The NETHERLANDS, BELGIUM, LUXEMBURG

Wim Kroon Import V.O.F., HV MILL, Tel. +31 485 453 911, Fax. +31 485 454 848

NORWAY

MC-Specialisten, SKÅRER, Tel. +47 67 920 380, Fax. +47 67 972 855

NEW ZEALAND

Hawera Motorcycles LMVD, HAWERA TARNAKI, Tel.+64 627 84160, Fax. +64 627 86552

POLAND

P.T.M. SP. zo.o., NIEPORET, Tel. +48 22 774 8978, Fax. +48 22 774 8978

PORTUGAL

Motoni, AMADORA, Tel. +351 1 472 8160, Fax. +351 1 471 4809

RUSSIA

Alpine Ltd, MOSCOW 121 552, Tel. +7 95 149 5069, Fax. +7 95 141 2310

SINGAPORE

Sporting Motorcycles, SINGAPORE 1232, Tel. +65 250 5508, Fax. +65 253 6312

SLOVENIA

Moto ZIP trgovina d.o.o., KRANJ, Tel: +386 64 26 85 15, Fax: +386 64 26 85 14

SOUTH AFRICA

Technical Motor Products, MIDRAND, Tel. +27 11 805 2471, Fax. +27 11 315 0472

SPAIN

Zacatin S.A., TORREJON DE ARDOZ, Tel. +34 1 677 7897, Fax. +34 1 677 6123

SWITZERLAND

3W Motorsport, WINTERTHUR, Tel. +41 52 315 3188, Fax. +41 52 315 3754

TAIWAN

Henly Company Ltd, TAIPEI 10422, Tel. +886 2 5375 600, Fax. +886 2 5631 357

TURKEY

Demaks Motor-Servis Hizmetleri A.S., ISTANBUL, Tel. +90 216 442 1580, Fax. +90 216 442 2380

U.K.

Harris Performance Prod. Ltd., HERTFORD, Tel. +44 1992 551 026, Fax. +44 1992 587 052

USA and CANADA

LeMans Corporation, JANESVILLE, WI 53547, Tel. +1 608 758 1111, Fax. +1 608 758 1144

service

Pettersson Pro Suspension, ANAHEIM, CA 92807, Tel. +1 714 630 4777, Fax. +1 714 630 4788

service

TUF Racing Products, DEKALB, IL 60115, Tel. +1 815 756 3588, Fax. +1 815 756 3528

(MX & Enduro steeringdampers)

Scotts Performance MC Products, MONTROSE, Tel. +1 818 248 6747, Fax. +1 818 248 4529

Öhlins Authorized Dealers in SWEDEN

Claessons Motor AB, Bromölla, Tel. 0456-230 30, Fax. 0456-232 31

R G Motor AB, Helsingborg, Tel. 042-16 96 60, Fax. 042-16 18 15

DML Pro Bike, Värnamo, Tel. 0370-271 00, Fax 0370-271 61

LEJ Motor AB, Skövde, Tel. 0500-48 11 95, Fax. 0500-46 17 14

Carlbarks Motor AB, Kumla, Tel. 019-57 07 01, Fax. 019-58 12 74

Beviks Motor AB, Linköping, Tel. 013-36 25 00, Fax. 013-36 25 10

BIKE Trollhättan AB, Trollhättan, Tel. 0520-700 75, Fax. 0520-762 84

Stötdämparexperten AB, Stockholm, Tel. 08-650 10 07, Fax. 08-650 10 09

Schneiders MC AB, Upplands Väsby, Tel. 08-590 310 80, Fax. 08-590 725 53

MB Racing AB, Västerås, Tel. 021-81 17 77, Fax. 021-81 17 78

Revelj Racing, Hede, Tel. 0684-120 59, Fax. 0684-122 75

Two Wheels i Umeå AB, Umeå, Tel. 090-187 595, Fax 090-18 77 61

Heds Motor AB, Boden, Tel. 0921-175 10, Fax.0921-162 20

Traction, handling,
comfort and safety



ADVANCED SUSPENSION TECHNOLOGY

Öhlins Racing AB, Box 722, S-194 27 Upplands Väsby, Sweden.
Phone +46 8 590 025 00, fax +46 8 590 025 80.

E-mail: info@ohlins.se